

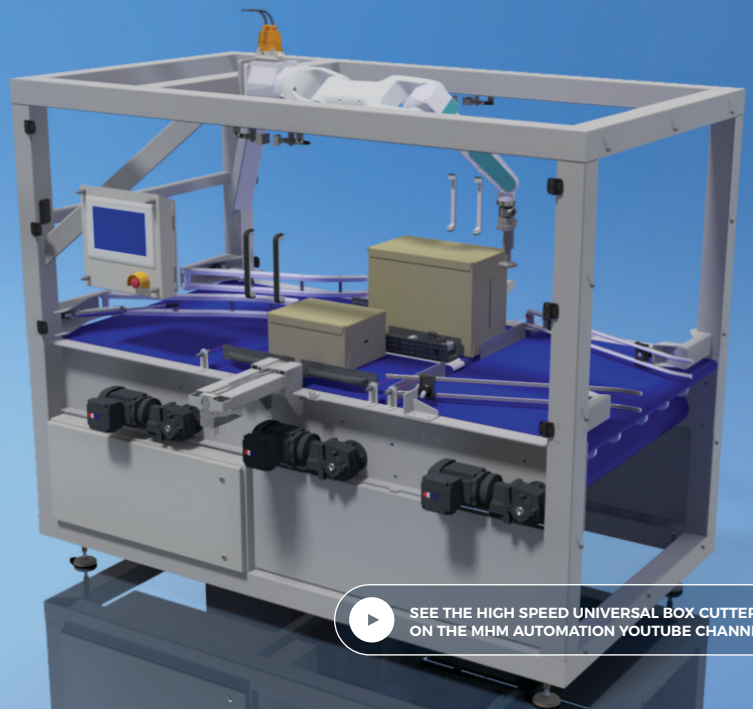

HIGH SPEED UNIVERSAL ROBOTIC BOX CUTTER

HS-UBC



SEE THE HIGH SPEED UNIVERSAL BOX CUTTER IN ACTION
ON THE MHM AUTOMATION YOUTUBE CHANNEL

Open boxes of varying shapes and sizes safely and efficiently, with high-speed operation.

This high-speed variation of the H&C Universal Box Cutter, or HS-UBC, automates the task of opening boxes and is capable of processing up to 16 boxes per minute through its twin lane configuration.

It uses the latest vision technology to automatically detect carton shape and size, and create real-time 3D images to determine the appropriate cut profile for each carton. It can open various carton sizes on the fly, without the need for operator intervention, and is even capable of processing damaged boxes.

MACHINE DIMENSIONS

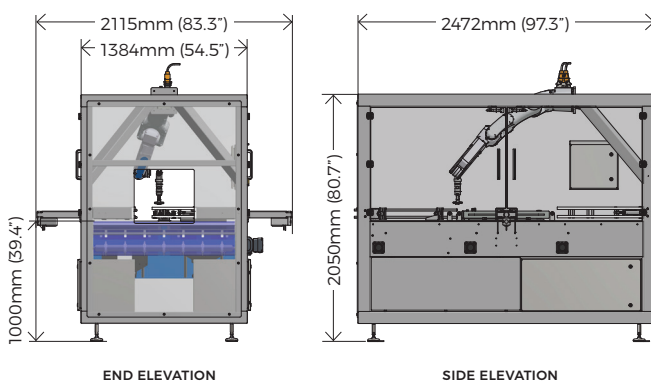

APPLICATIONS

- > Operations where product is required to be removed from corrugated cardboard boxes
- > Suitable for non-sanitary applications
- > Line speeds of up to 16 boxes per minute

BOX SIZE RANGE

	MIN	MAX
Length	150mm - 6"	600mm - 23.6"
Width	120mm - 4.7"	350mm - 13.78"
Height	130mm - 5.1"	300mm - 11.8"
or	100mm 4" if W <300mm 11.8"	450mm 17.7" if L <400mm 15.75"
Weight	5kg - 10.4lb	50kg - 110lb

BENEFITS

- > A single machine which handles multiple carton formats at the same time
- > Fully automated - operator input not required
- > Reduces labour requirements, allowing staff to be re-deployed to higher value work
- > Eliminates manual handling, knives and the associated risk of injury

FEATURES

- > Capable of handling damaged cartons
- > Capable of cutting carton straps and bands
- > Cut profiles can be customised
- > Can be used as a standalone solution or integrated with other automated systems including depalletising, product unloading and conveying